

## Chapter 5: Oscillations

---

### EXERCISES [PAGES 129 - 130]

#### Exercises | Q 1.1 | Page 129

**Choose the correct option:**

A particle performs linear S.H.M. starting from the mean position. Its amplitude is A and time period is T. At the instance when its speed is half the maximum speed, its displacement x is

- $\frac{\sqrt{3}}{2} A$
- $\frac{2}{2} A$
- $\frac{\sqrt{3}}{A}$
- $\frac{2}{1} A$
- $\frac{1}{\sqrt{2}} A$

### SOLUTION

$$\frac{\sqrt{3}}{2} A$$

#### Exercises | Q 1.2 | Page 129

**Choose the correct option:**

A body of mass 1 kg is performing linear S.H.M. Its displacement x (cm) at t(second) is given by  $x = 6 \sin$

$\left(100t + \frac{\pi}{4}\right)$ . Maximum kinetic energy of the body is

36 J

9 J

27 J

**18 J**

### SOLUTION

18 J

Exercises | Q 1.3 | Page 129

**Choose the correct option:**

The length of second's pendulum on the surface of earth is nearly 1 m. Its length on the surface of moon should be [Given: acceleration due to gravity (g) on moon is 1/6 th of that on the earth's surface]

$$\frac{1}{6} \text{ m}$$

$$6 \text{ m}$$

$$\frac{1}{36} \text{ m}$$

$$\frac{1}{\sqrt{6}} \text{ m}$$

**SOLUTION**

$$\frac{1}{6} \text{ m}$$

Exercises | Q 1.4 | Page 129

**Choose the correct option:**

Two identical springs of constant k are connected, first in series and then in parallel. A metal block of mass m is suspended from their combination. The ratio of their frequencies of vertical oscillations will be in a ratio

1. 1:4

2. 1:2

3. 2:1

4. 4:1

**SOLUTION**

1:2

Exercises | Q 1.5 | Page 129

**Choose the correct option:**

The graph shows variation of displacement of a particle performing S.H.M. with time t. Which of the following statements is correct from the graph?

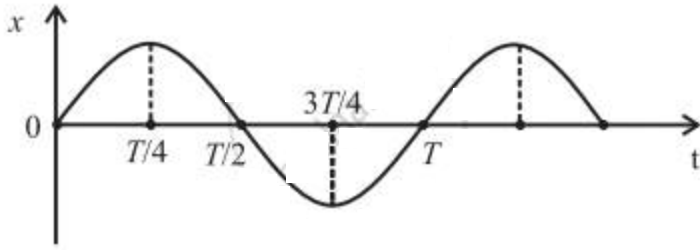

The acceleration is maximum at time  $T$ .

**The force is maximum at time  $\frac{3T}{4}$ .**

The velocity is zero at time  $\frac{T}{2}$ .

The kinetic energy is equal to total energy at a time  $\frac{T}{4}$ .

**SOLUTION**

**The force is maximum at a time  $\frac{3T}{4}$ .**

**Exercises | Q 2.1 | Page 129**

Define linear simple harmonic motion.

**SOLUTION**

Linear simple harmonic motion (S.H.M.) is defined as the linear periodic motion of a body, in which the restoring force (or acceleration) is always directed towards the mean position and its magnitude is directly proportional to the displacement from the mean position.

**Exercises | Q 2.2 | Page 129**

**Answer in brief.**

Using differential equations of linear S.H.M, obtain the expression for (a) velocity in S.H.M., (b) acceleration in S.H.M.

**SOLUTION**

The general expression for the displacement of a particle in S.H.M. at time  $t$  is

$$x = A \sin (\omega t + \phi) \dots\dots\dots(1)$$

where  $A$  is the amplitude,  $\omega$  is a constant in a particular case, and  $\phi$  is the initial phase. The velocity of the particle is

$$v = \frac{dx}{dt} = \frac{d}{dt} \dots\dots\dots[A \sin (\omega t + x)]$$

$$= \omega A \cos (\omega t + x)$$

$$= \omega A \sqrt{1 - \sin^2(\omega t + x)}$$

From Eq. (1),  $\sin (\omega t + x) = x/A$

$$\therefore v = \omega A \sqrt{1 - \frac{x^2}{A^2}}$$

$$\therefore v = \omega \sqrt{A^2 - x^2} \dots\dots\dots(2)$$

Equation (2) gives the velocity as a function of x. The acceleration of the particle is

$$a = \frac{dv}{dt} = \frac{d}{dt} \dots\dots[A\omega \cos (\omega t + x)]$$

$$\therefore a = -\omega^2 A \sin (\omega t + x)$$

But from Eq. (1),  $A \sin (\omega t + x) = x$

$$\therefore a = -\omega^2 x \dots\dots\dots(3)$$

Equation (3) gives the acceleration as a function of x. The minus sign shows that the direction of the acceleration is opposite to that of the displacement.

### Exercises | Q 2.3 | Page 129

#### Answer in brief.

Obtain the expression for the period of a simple pendulum performing S.H.M.

## SOLUTION

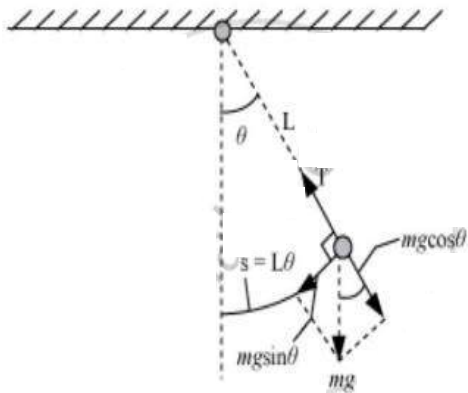

Let  $m$  is Mass of the bob.

$L$  is the Length of mass-less string.

A free-body diagram to the forces acting on the bob,

$\theta$  – angle made by the string with the vertical.

$T$  is tension along the string

$g$  is the acceleration due to gravity

Radial acceleration =  $\omega^2 L$

Net radial force =  $T - mg \cos \theta$

Tangential acceleration is provided by  $mg \sin \theta$ .

Torques,  $\tau = -L (mg \sin \theta)$

According to Newton's law of rotational motion,

$\tau = I\alpha$

Where,  $I$  is the moment of inertia

$\alpha$  – Angular acceleration

$\therefore I\alpha = -mg \sin \theta L$

If  $\theta$  is very small, then

$\sin \theta \approx \theta$

so,  $I\alpha = -mg\theta L = -(mgL)\theta$

We know, it will follow simple harmonic motion when  $\alpha = -\omega^2\theta$

So,  $I(-\omega^2\theta) = -(mgL)\theta$

Moment of inertia,  $I = mL^2$

$$\text{So, } mL^2\omega^2 = mgL$$

$$\omega = \sqrt{\frac{g}{L}}$$

$$T = \frac{2\pi}{\omega} = 2\pi\sqrt{\frac{L}{g}}$$

Here it is clear that the time period of a simple pendulum is directly proportional to the square root of the length of the pendulum and inversely proportional to the square root of acceleration due to gravity.

### Exercises | Q 2.4 | Page 129

**Answer in brief.**

State the law of simple pendulum.

#### **SOLUTION**

The period of a simple pendulum at a given place is

$$T = 2\pi \sqrt{\frac{L}{g}}$$

where  $L$  is the length of the simple pendulum and  $g$  is the acceleration due to gravity at that place. From the above expression, the laws of a simple pendulum are as follows:

- **Law of length:** The period of a simple pendulum at a given place ( $g$  constant) is directly proportional to the square root of its length.  
 $\therefore T \propto \sqrt{L}$
- **Law of acceleration due to gravity:** The period of a simple pendulum of a given length ( $L$  constant) is inversely proportional to the square root of the acceleration due to gravity.  
 $\therefore T \propto \frac{1}{\sqrt{g}}$
- **Law of mass:** The period of a simple pendulum does not depend on the mass of material of the bob of the pendulum.
- **Law of isochronism:** The period of a simple pendulum does not depend on the amplitude of oscillations, provided that the amplitude is small.

### Exercises | Q 2.5 | Page 129

**Answer in brief.**

Prove that under certain conditions a magnet vibrating in a uniform magnetic field performs angular S.H.M.

#### **SOLUTION**

Consider a bar magnet of the magnetic moment  $\mu$ , suspended horizontally by a light twistless fiber in a region where the horizontal component of the Earth's magnetic field is  $B$ . The bar magnet is free to rotate in a horizontal plane. It comes to rest in approximately the North-South direction, along with  $B$ . If it is rotated in the horizontal plane by a small

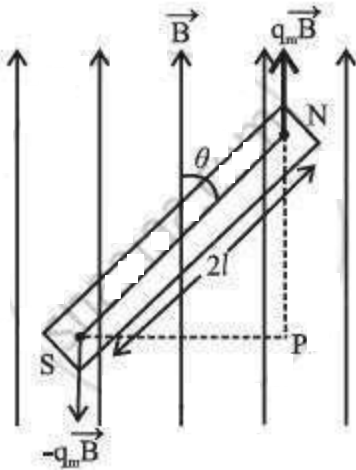

displacement  $\theta$  from its rest position ( $\theta = 0$ ), the suspension fiber is twisted. When the magnet is released, it oscillates about the rest position in angular or torsional oscillation.

The bar magnet experiences a torque  $\tau$  due to field  $B$ . This tends to restore it to its original orientation parallel to  $B$ . For small  $\theta$ , this restoring torque is  $\Gamma = \mu B \theta$  .....(1)

where the minus sign indicates that the torque is opposite in direction to the angular displacement  $\theta$ . Equation (1) shows that the torque (and hence the angular acceleration) is directly proportional to the magnitude of the angular displacement but opposite in direction. Hence, for small angular displacement, the oscillations of the bar magnet in a uniform magnetic field are simple harmonic.

**Exercises | Q 3 | Page 129**

**Answer in brief:**

Obtain the expression for the period of a magnet vibrating in a uniform magnetic field and performing S.H.M.

**SOLUTION**

The expression is given as  $T = 2\pi \sqrt{\frac{I}{m B}}$

**Explanation:**

The time period of oscillation of a magnet in a uniform magnetic field 'B' is given by

**Formula:**

$$T = 2\pi \sqrt{\frac{I}{m B}}$$

Where

- $T$  = Time period
- $I$  = Moment of inertia
- $M$  = mass of bob
- $B$  = magnetic field

Time period of an oscillation body about a fixed point can be defined as the time taken by the body to complete one vibration around that particular point is called time period.

### Exercises | Q 4 | Page 129

Show that S.H.M. is a projection of U.C.M. on any diameter

#### **SOLUTION**

Linear S.H.M. is defined as the linear periodic motion of a body, in which the restoring force (or acceleration) is always directed towards the mean position and its magnitude is directly proportional to the displacement from the mean position.

There is basic relation between S.H.M. and U.C.M. that is very useful in understanding S.H.M. For an object performing U.C.M. the projection of its motion along any diameter of its path executes S.H.M.

Consider particle 'P' is moving along the circumference of circle of radius 'a' with constant angular speed of  $\omega$  in anticlockwise direction as shown in figure. Particle P along circumference of circle has its projection particle on diameter AB at point M. Particle P is called reference particle and the circle on which it moves, its projection moves back and forth along the horizontal diameter, AB.

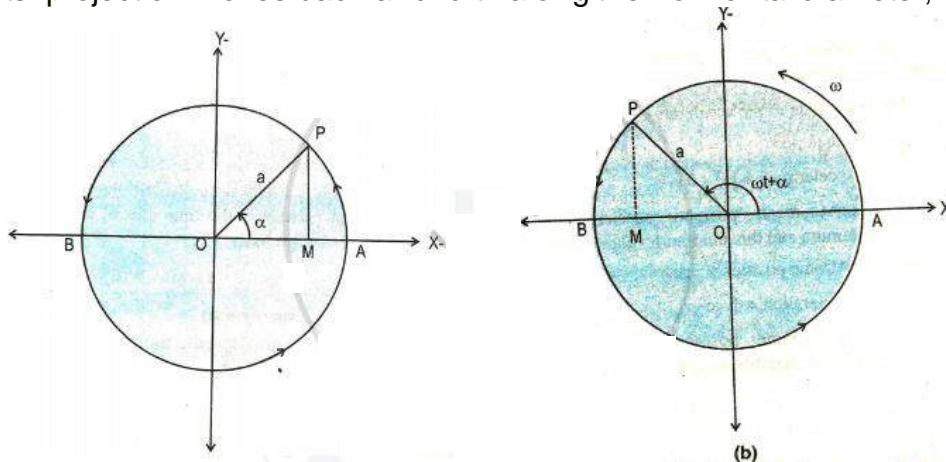

The x-component of the displacement of P is always same as displacement of M, the x-component of the velocity of P is always same as velocity of M and the x-component of the acceleration of M.

Suppose that particle P starts from initial position with initial phase  $\alpha$  (angle between



radius OP and the x – axis at the time t = 0) In time t the angle between OP and x - axis is (  $\omega t + \alpha$  ) as particle P moving with constant angular velocity ( $\omega$ ) as shown in figure.

$$\cos(\omega t + \alpha) = \frac{x}{a}$$

$$\therefore x = a \cos(\omega t + \alpha) \quad \dots\dots(1)$$

This is the expression for displacement of particle M at time t.

As velocity of the particle is the time rate of change of displacement then we have

$$v = \frac{dx}{dt} = \frac{d}{dt} [a \cos(\omega t + \alpha)]$$

$$\therefore v = -a\omega \sin(\omega t + \alpha) \quad \dots\dots(2)$$

As acceleration of particle is the time rate of change of velocity, we have

$$a = \frac{dv}{dt} = \frac{d}{dt} [-a\omega \sin(\omega t + \alpha)]$$

$$\therefore a = -a\omega^2 \cos(\omega t + \alpha)$$

$$\therefore a = \omega^2 x$$

It shows that acceleration of particle M is directly proportional to its displacement and its direction is opposite to that of displacement.

Thus particle M performs simple harmonic motion but M is projection of particle performing U.C.M. hence S.H.M. is projection of U.C.M. along a diameter, of circle.

### Exercises | Q 5 | Page 129

Draw graphs of displacement, velocity, and acceleration against phase angle, for a particle performing linear S.H.M. from (a) the mean position (b) the positive extreme position. Deduce your conclusions from the graph.

### **SOLUTION**

Consider a particle performing S.H.M., with amplitude A and period  $T = 2\pi/\omega$  starting from the mean position towards the positive extreme position where  $\omega$  is the angular frequency. Its displacement from the mean position (x), velocity (v), and acceleration (a) at any instant are

$$x = A \sin \omega t = A \sin \left( \frac{2\pi}{T} t \right) \dots\dots \left( \because \omega = \frac{2\pi}{T} \right)$$

$$v = \frac{dv}{dt} = \omega A \cos \omega t = \omega A \cos \left( \frac{2\pi}{T} t \right)$$

$$a = -\omega^2 A \sin \omega t = -\omega^2 A \sin \left( \frac{2\pi}{T} t \right)$$

as the initial phase  $x = 0$ .

as the initial phase  $x = 0$ .

Using these expressions, the values of  $x$ ,  $v$ , and  $a$  at the end of every quarter of a period, starting from  $t = 0$ , are tabulated below.

$t$	0	$\frac{T}{4}$	$\frac{T}{2}$	$\frac{3T}{4}$	$T$
$\omega t$	0	$\frac{\pi}{2}$	$\pi$	$\frac{3\pi}{2}$	$2\pi$
$x$	0	$A$	0	$-A$	0
$v$	$\omega A$	0	$-\omega A$	0	$\omega A$
$a$	0	$-\omega^2 A$	0	$\omega^2 A$	0

Using the values in the table we can plot graphs of displacement, velocity, and acceleration with time

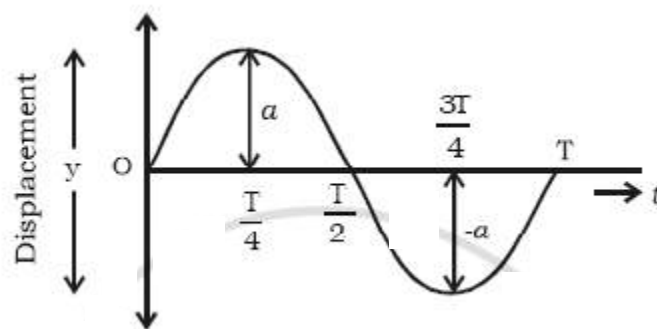

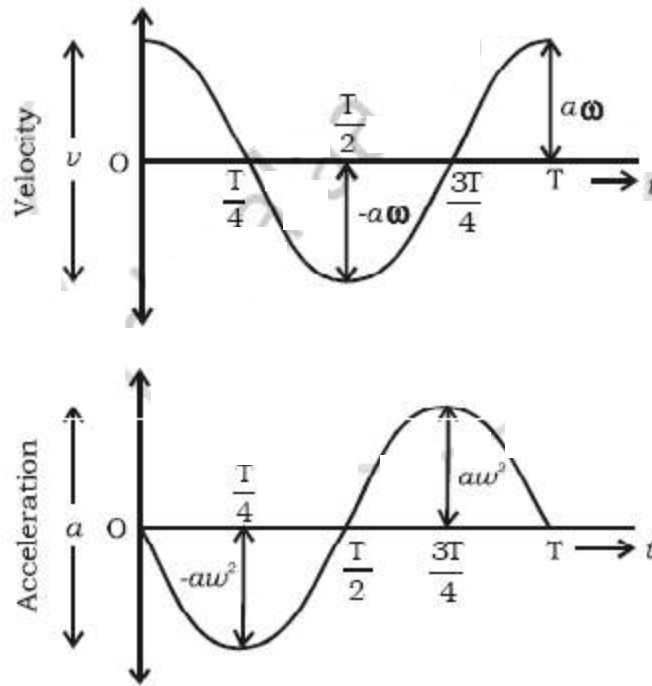

**Graphs of displacement, velocity, and acceleration with time for a particle in SHM starting from the mean position**

**Conclusions:**

- The displacement, velocity, and acceleration of a particle performing linear SHM are periodic (harmonic) functions of time. For a particle starting at the mean position, the  $x-t$  and  $a-t$  graph are sine curves. The  $v-t$  graph is a cosine curve.
- There is a phase difference of  $\frac{\pi}{2}$  radians between  $x$  and  $v$ , and between  $v$  and  $a$ .
- There is a phase difference of  $\pi$  radians between  $x$  and  $a$ .

**Exercises | Q 6 | Page 129**

Deduce the expressions for the kinetic energy and potential energy of a particle executing S.H.M. Hence obtain the expression for the total energy of a particle performing S.H.M and show that the total energy is conserved. State the factors on which total energy depends.

**SOLUTION**

Consider a particle of mass  $m$  performing linear S.H.M. with amplitude  $A$ . The restoring force acting on the particle is  $F = -kx$ , where  $k$  is the force constant and  $x$  is the displacement of the particle from its mean position.

**(1) Kinetic energy:** At distance  $x$  from the mean position, the velocity is

$$v = \omega \sqrt{A^2 - x^2}$$

where  $\omega = \sqrt{k/m}$ . The kinetic energy (KE) of the particle is

$$\begin{aligned} \text{KE} &= \frac{1}{2}mv^2 = \frac{1}{2}m\omega^2(A^2 - x^2) \\ &= \frac{1}{2}k(A^2 - x^2) \dots\dots\dots(1) \end{aligned}$$

If the phase of the particle at an instant  $t$  is  $\theta = \omega t + x$ , where  $a$  is the initial phase, its velocity at that instant is

$$v = \omega A \cos(\omega t + x)$$

and its KE at that instant is

$$\begin{aligned} \text{KE} &= \frac{1}{2}mv^2 = \frac{1}{2}m\omega^2A^2 \cos^2(\omega t + x) \\ &= \frac{1}{2}kA^2 \cos^2(\omega t + x) \dots\dots(2) \end{aligned}$$

Therefore, the KE varies with time as  $\cos^2\theta$ .

**(2) Potential energy:** Consider a particle of mass  $m$ , performing a linear S.H.M. along the path MN about the mean position O. At a given instant, let the particle be at P, at a distance  $x$  from O.

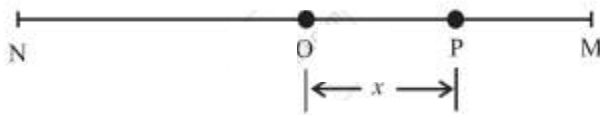

Potential energy of a particle in SHM

The corresponding work done by the external agent will be  $dW = (-F)dx = kx dx$ . This work done is stored in the form of potential energy.

The potential energy (PE) of the particle when its displacement from the mean position is  $x$  can be found by integrating the above expression from 0 to  $x$ .

$$\therefore PE = \int dW = \int_0^x kx \, dx = \frac{1}{2} kx^2 \dots\dots\dots(3)$$

The displacement of the particle at an instant t being

$$x = A \sin (\omega t + \phi)$$

its PE at that instant is

$$PE = \frac{1}{2} kx^2 = \frac{1}{2} kA^2 \sin^2(\omega t + \phi) \dots\dots\dots(4)$$

Therefore, the PE varies with time as  $\sin^2\theta$

**(3) Total energy:** The total energy of the particle is equal to the sum of its potential energy and kinetic energy.

From Eqs. (1) and (2), total energy is

$$\begin{aligned} &= \frac{1}{2} kx^2 + \frac{1}{2} k (A^2 - x^2) \\ &= \frac{1}{2} kx^2 + \frac{1}{2} kA^2 - \frac{1}{2} kx^2 \\ \therefore E &= \frac{1}{2} kA^2 = \frac{1}{2} m\omega^2 A^2 \dots\dots(5) \end{aligned}$$

As m is constant, and  $\omega$  and A are constants of the motion, the total energy of the particle remains constant (or it's conserved).

### Exercises | Q 7 | Page 129

#### Answer in brief:

Derive an expression for the period of motion of a simple pendulum. On which factors does it depend?

#### **SOLUTION**

a) Consider a simple pendulum of mass 'm' and length 'L'.

$$L = l + r,$$

where l = length of string

r = radius of bob

b) Let OA be the initial position of pendulum and OB, its instantaneous position when the string makes an angle  $\theta$  with the vertical.

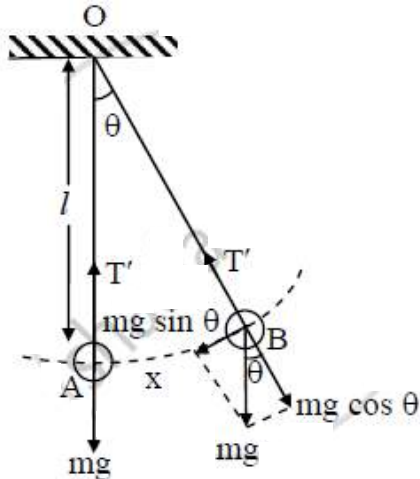

In the displaced position, two forces are acting on the bob:

- Gravitational force (weight) 'mg' in a downward direction
- Tension T' in the string.

c) Weight 'mg' can be resolved into two rectangular components:

- Radial component  $mg \cos \theta$  along OB and
- Tangential component  $mg \sin \theta$  perpendicular to OB and directed towards mean position.

d)  $mg \cos \theta$  is balanced by tension T' in the string, while  $mg \sin \theta$  provides restoring force

$$\therefore F = - mg \sin \theta$$

where a negative sign shows that force and angular displacement are oppositely directed.

Hence, restoring force is proportional to  $\sin \theta$  instead of  $\theta$ . So, the resulting motion is not S.H.M.

e) If  $\theta$  is very small then,

$$\sin \theta \approx \theta = \frac{x}{L}$$

$$\therefore F = -mg \frac{x}{L}$$

$$\therefore \frac{F}{m} = -g \frac{x}{L}$$

$$\therefore \frac{ma}{m} = -g \frac{x}{L}$$

$$\therefore "a" = - "g"/"L" "x" \dots(i)$$

$$\therefore a \propto -x \quad \dots \left[ \because \frac{g}{L} = \text{constant} \right]$$

f) In S.H.M,

$$a = -\omega^2 x \quad \dots \text{(ii)}$$

Comparing equations (i) and (ii), we get,

$$\omega^2 = \frac{g}{L}$$

$$\text{But, } \omega = \frac{2\pi}{T}$$

$$\therefore \left( \frac{2\pi}{T} \right)^2 = \frac{g}{L}$$

$$\therefore \frac{2\pi}{T} = \sqrt{\frac{g}{L}}$$

$$\therefore T = 2\pi \sqrt{\frac{L}{g}} \quad \dots \text{(iii)}$$

Equation (iii) represents time period of simple pendulum.

g) Thus period of a simple pendulum depends on the length of the pendulum and acceleration due to gravity.

### Exercises | Q 8 | Page 129

At what distance from the mean position is the speed of a particle performing S.H.M. half its maximum speed. Given the path length of S.H.M. = 10 cm.

#### **SOLUTION**

$$\text{Data: } v = \frac{1}{2} v_{\max}, \quad 2A = 10 \text{ cm}$$

$$\therefore a = 5 \text{ cm}$$

$$v = \omega \sqrt{A^2 - x^2} \quad \text{and } v_{\max} = \omega A$$

$$\text{since } c = \frac{1}{2}v_{\max}$$

$$\omega\sqrt{A^2 - x^2} = \frac{\omega A}{2}$$

$$\therefore A^2 - x^2 = \frac{A^2}{4}$$

$$\therefore x^2 = A^2 - \frac{A^2}{4} = \frac{3A^2}{4}$$

$$\therefore x = \pm \frac{\sqrt{3}}{2}A = \pm 0.866 \times 5 = \pm 4.33 \text{ cm}$$

This gives the required displacement.

### Exercises | Q 9 | Page 130

In SI units, the differential equation of an S.H.M. is  $d^2x/dt^2 = -36x$ . Find its frequency and period.

#### **SOLUTION**

$$\frac{d^2x}{dt^2} = -36x$$

Comparing this equation with the general equation,

$$\frac{d^2x}{dt^2} = -\omega^2x$$

We get,  $\omega^2 = 36 \therefore \omega = 6 \text{ rad/s}$

$$\omega = 2\pi f$$

$$\therefore \text{The frequency, } f = \frac{\omega}{2\pi} = \frac{6}{2(3.142)} = \frac{6}{6.284} = 0.9548 \text{ Hz}$$

$$\text{and the period, } T = \frac{1}{f} = \frac{1}{0.9548} = 1.047 \text{ s}$$



### Exercises | Q 10 | Page 130

A needle of a sewing machine moves along a path of amplitude 4 cm with a frequency of 5 Hz. Find its acceleration (1/30) s after it has crossed the mean position.

#### **SOLUTION**

**Data:**  $A = 4 \text{ cm} = 4 \times 10^{-2} \text{ m}$ ,  $f = 5 \text{ Hz}$ ,  $t = \left(\frac{1}{30}\right) \text{ s}$

$$\omega = 2\pi f = 2\pi(5) = 10\pi \text{ rad/s}$$

Therefore, the magnitude of the acceleration,

$$|a| = \omega^2 x = \omega^2 A \sin \omega t$$

$$= (10\pi)^2 (4 \times 10^{-2})$$

$$= 10\pi^2 \sin \frac{\pi}{3}$$

$$= 10(9.872)(0.866)$$

$$= 34.20 \text{ m/s}^2$$

### Exercises | Q 11 | Page 130

Potential energy of a particle performing linear S.H.M. is  $0.1\pi^2 x^2$  joule. If the mass of the particle is 20 g, find the frequency of S.H.M.

#### **SOLUTION**

**Data:**  $PE = 0.1\pi^2 x^2 \text{ J}$ ,  $m = 20 \text{ g} = 2 \times 10^{-2} \text{ kg}$

$$PE = \frac{1}{2} m \omega^2 x^2 = \frac{1}{2} m (4\pi^2 f^2) x^2$$

$$\therefore \frac{1}{2} m (4\pi^2 f^2) x^2 = 0.1\pi^2 x^2$$

$$\therefore 2mf^2 = 0.1$$

$$\therefore f^2 = \frac{1}{20(2 \times 10^{-2})} = 2.5$$

$\therefore$  The frequency of SHM is

$$f = \sqrt{2.5} = 1.581 \text{ Hz}$$

### Exercises | Q 12 | Page 130

The total energy of a body of mass 2 kg performing S.H.M. is 40 J. Find its speed while crossing the center of the path.

#### SOLUTION

**Given:**

Mass =  $m = 2 \text{ kg}$ ,

Energy =  $E = 40 \text{ J}$

The speed of the body while crossing the centre of the path (mean position) is  $V_{\max}$  and the total energy is entirely kinetic energy.

$$\therefore \frac{1}{2} m v_{\max}^2 = E$$

$$\therefore v_{\max} = \sqrt{\frac{2E}{m}} = \sqrt{\frac{2 \times 40}{2}} = 6.324 \text{ m/s}$$

### Exercises | Q 13 | Page 130

A simple pendulum performs S.H.M. of period 4 seconds. How much time after crossing the mean position, will the displacement of the bob be one-third of its amplitude.

#### SOLUTION

**Data:**  $T = 4 \text{ s}$ ,  $x = A/3$

The displacement of a particle starting into SHM from the mean position is  $x = A \sin \omega t = A \sin \frac{2\pi}{T} t$

$$\therefore A \sin \frac{2\pi}{T} t = \frac{A}{3}$$

$$\therefore \frac{2\pi}{T} t = \sin^{-1} 0.3333 = 19.47^\circ = 19.47 \times \frac{\pi}{180} \text{ rad}$$

$$\therefore \frac{2}{4} t = \frac{19.47}{180}$$

$$\therefore t = \frac{19.47}{90} = 0.2163 \text{ s}$$

$\therefore$  The displacement of the bob will be one-third of its amplitude 0.2163 s after crossing the mean position.

### Exercises | Q 14 | Page 130

A simple pendulum of length 100 cm performs S.H.M. Find the restoring force acting on its bob of mass 50 g when the displacement from the mean position is 3 cm.

#### **SOLUTION**

**Data:**  $L = 100 \text{ cm}$ ,  $m = 50 \text{ g} = 5 \times 10^{-2} \text{ kg}$ ,  $x = 3 \text{ cm}$ ,

$$g = 9.8 \text{ m/s}^2$$

We know that

Restoring force,  $F = mg \sin\theta = mg\theta$

$$= (5 \times 10^{-2})(9.8) \left( \frac{3}{100} \right)$$

$$= 1.47 \times 10^{-2} \text{ N}$$

### Exercises | Q 15 | Page 130

Find the change in length of a second's pendulum, if the acceleration due to gravity at the place changes from  $9.75 \text{ m/s}^2$  to  $9.8 \text{ m/s}^2$ .

#### **SOLUTION**

**Data:**  $g_1 = 9.75 \text{ m/s}^2$ ,  $g_2 = 9.8 \text{ m/s}^2$

Length of a seconds pendulum,  $L = \frac{g}{\pi^2}$

$$\therefore L_1 = \frac{g_1}{\pi^2} = \frac{9.75}{9.872} = 0.9876 \text{ m}$$

$$\text{and } L_2 = \frac{g_2}{\pi^2} = \frac{9.8}{9.872} = 0.9927 \text{ m}$$

$\therefore$  The length of the second's pendulum must be increased from 0.9876 m to 0.9927 m, i.e., by 0.0051 m.

### Exercises | Q 16 | Page 130

At what distance from the mean position is the kinetic energy of a particle performing S.H.M. of amplitude 8 cm, three times its potential energy?

### **SOLUTION**

**Data:**  $A = 8 \text{ cm}$ ,  $KE = 3 \text{ PE}$

$$KE = \frac{1}{2}k(A^2 - x^2) \text{ and } PE = \frac{1}{2}kx^2$$

Given,  $KE = 3PE$ .

$$\therefore \frac{1}{2}k(A^2 - x^2) = 3\left(\frac{1}{2}kx^2\right)$$

$$\therefore A^2 - x^2 = 3x^2$$

$$\therefore 4x^2 = A^2$$

$\therefore$  the required displacement is

$$x = \pm \frac{A}{2} = \pm \frac{8}{2} = \pm 4 \text{ cm}$$

### **Exercises | Q 17 | Page 130**

A particle performing linear S.H.M. of period  $2\pi$  seconds about the mean position O is observed to have a speed of  $b\sqrt{3}$  m/s, when at a distance b (metre) from O. If the particle is moving away from O at that instant, find the time required by the particle, to travel a further distance b.

### **SOLUTION**

**Given:**

$$\text{The time period of the particle} = \frac{2\pi}{\omega}$$

$$\text{Speed of the particle} = b\omega\sqrt{3} \text{ m/s}$$

**To Find:**

The time required by the particle to travel a distance of bm

The velocity of particle is given by

$$v = \omega \sqrt{A^2 - x^2}$$

By substituting the values

$$b\omega\sqrt{3} = \omega \sqrt{A^2 - b^2}$$

$$3b^2\omega^2 = \omega^2(A^2 - b^2)$$

$$3b^2 = (A^2 - b^2)$$

$$4b^2 = A^2$$

$$A = 2b$$

The time taken to travel distance  $b$  from mean position is

$$x = A \sin \omega t$$

$$b = 2b \sin \omega t$$

$$\sin \omega t = \frac{1}{2}$$

$$t = \frac{\pi}{6\omega}$$

Further time taken by the particle to reach mean position is

$$t = \frac{T}{4} - \frac{\pi}{6\omega}$$

$$t = \frac{2\pi}{4\omega} - \frac{\pi}{6\omega}$$

$$t = \frac{\pi}{3\omega}$$

**The time required by the particle is  $\frac{\pi}{3\omega}$  sec**

### Exercises | Q 18 | Page 130

The period of oscillation of a body of mass  $m_1$  suspended from a light spring is  $T$ . When a body of mass  $m_2$  is tied to the first body and the system is made to oscillate, the period is  $2T$ . Compare the masses  $m_1$  and  $m_2$

**SOLUTION**

$$T = 2\pi\sqrt{\frac{m}{k}}$$

$$\therefore \frac{2T}{T} = 2 = \sqrt{\frac{m_1 + m_2}{m_1}}$$

$$\therefore \frac{m_1 + m_2}{m_1} = 4$$

$$\therefore \frac{m_2}{m_1} = \frac{3}{1}$$

$$\therefore \frac{m_1}{m_2} = \frac{1}{3}$$

This gives the required ratio of the masses.

**Exercises | Q 19 | Page 130****Answer in brief:**

The displacement of an oscillating particle is given by  $x = a \sin \omega t + b \cos \omega t$  where  $a$ ,  $b$  and  $\omega$  are constants. Prove that the particle performs a linear S.H.M. with amplitude  $A$

$$= \sqrt{a^2 + b^2}$$

**SOLUTION**

Position of particles is given by,

$$y = A \cos \omega t + B \sin \omega t \quad \dots(1)$$

The velocity of particle is given by,

$$v = \frac{dy}{dt} = \frac{d}{dt} (A \cos \omega t + B \sin \omega t)$$

$$= -A\omega \sin \omega t + B\omega \cos \omega t$$

Acceleration of particle is given by,

$$a = \frac{dv}{dt} = \frac{d}{dt} (-A\omega \sin \omega t + B\omega \cos \omega t)$$

$$= -A\omega^2 \cos \omega t + B\omega^2 \sin \omega t$$

$$= -\omega^2 (A \cos \omega t + B \sin \omega t)$$

$$= -\omega^2 y$$

Since the acceleration of particles is directly proportional to displacement and directed towards mean position, therefore type motion is simple harmonic motion.

Now,

$$\text{Let amplitude } A = r \sin \phi \dots(2)$$

$$\text{and } B = r \cos \phi \dots(3)$$

Substituting A and B in (1), we get

$$y = r \sin \phi \cos \omega t + r \cos \phi \sin \omega t$$

$$= r(\cos \omega t \sin \phi + \sin \omega t \cos \phi)$$

$$= r \sin (\omega t + \phi)$$

Squaring (2) and (3) and adding, we have

$$A^2 + B^2 = r^2$$

$$\Rightarrow r \sqrt{A^2 + B^2}$$

Dividing (2) (3), we have

$$\frac{A}{B} = \tan \phi$$

$$\Rightarrow r \sqrt{A^2 + B^2}$$

Therefore

$$\text{Amplitude} = r \sqrt{A^2 + B^2}$$

### Exercises | Q 20 | Page 130

Two parallel S.H.M.s represented by

$x_1 = 5 \sin \left( 4\pi t + \frac{\pi}{3} \right)$  cm and  $x_2 = 3 \sin \left( 4\pi t + \frac{\pi}{4} \right)$  cm are superposed on a particle. Determine the amplitude and epoch of the resultant S.H.M.

### **SOLUTION**

#### **Given:**

Two parallel S.H.Ms represented by

$x_1 = 5 \sin\left(4\pi t + \frac{\pi}{3}\right)$  cm and  $x_2 = 3 \sin\left(4\pi t + \frac{\pi}{4}\right)$  cm are superposed on a particle.

**To find:** The amplitude and epoch of the resultant SHM.

using superposition principle,

amplitude of resultant is given by,

$$A = \sqrt{A_1^2 + A_2^2 + 2A_1A_2\cos\phi}$$

$$\text{here, } A_1 = 5, A_2 = 3 \text{ and } \Phi = \frac{\pi}{3} - \frac{\pi}{4} = \frac{\pi}{12}$$

$$\text{now } A = \sqrt{5^2 + 3^2 + 2(5)(3)\cos\left(\frac{\pi}{12}\right)}$$

$$= \sqrt{25 + 9 + 30 \times 0.966}$$

$$= \sqrt{62.98}$$

$$= 7.936 \text{ cm}$$

$$\text{epoch of the resultant, } \theta = \tan^{-1} \left[ \frac{A_1\sin\Phi_1 + A_2\sin\Phi_2}{A_1\cos\Phi_1 + A_2\cos\Phi_2} \right]$$

$$= \tan^{-1} \left[ \frac{5 \sin\left(\frac{\pi}{3}\right) + 3 \sin\left(\frac{\pi}{4}\right)}{5 \cos\left(\frac{\pi}{3}\right) + 3 \cos\left(\frac{\pi}{4}\right)} \right]$$

$$= \tan^{-1} \left[ \frac{5 \times \sqrt{\frac{3}{2}} + 3 \times \frac{1}{\sqrt{2}}}{5 \times \frac{1}{2} + 3 \times \frac{1}{\sqrt{2}}} \right]$$



$$= \tan^{-1} \left[ \frac{5\sqrt{3} + 3\sqrt{2}}{5 + 3\sqrt{2}} \right]$$

$$= 54^\circ 23'$$

Therefore amplitude is 7.936 cm and epoch of the resultant is  $54^\circ 23'$

### Exercises | Q 21 | Page 130

A 20 cm wide thin circular disc of mass 200 g is suspended to rigid support from a thin metallic string. By holding the rim of the disc, the string is twisted through  $60^\circ$  and released. It now performs angular oscillations of period 1 second. Calculate the maximum restoring torque generated in the string under undamped conditions. ( $\pi^3 \approx 31$ )

### SOLUTION

**Data:**  $R = 10 \text{ cm} = 0.1 \text{ m}$ ,  $M = 0.2 \text{ kg}$ ,  $\theta_m = 60^\circ = \frac{\pi}{3} \text{ rad}$ ,  $T = 1 \text{ s}$ ,  $\pi^3 \approx 31$

The MI of the disc about the rotation axis (perpendicular through its centre) is

$$I = \frac{1}{2}MR^2 = \frac{1}{2}(0.2)(0.1)^2 = 10^{-3} \text{ kg.m}^2$$

The period of torsional oscillation,  $T = 2\pi\sqrt{\frac{I}{c}}$

$$\therefore \text{The torsion constant, } c = 4\pi^2 \frac{I}{T^2}$$

The magnitude of the maximum restoring torque,

$$\tau_{\max} = c\theta_m = \left(4\pi^2 \frac{I}{T^2}\right) \left(\frac{\pi}{3}\right)$$

$$= \frac{4}{3}\pi^3 \frac{I}{T^2} = \frac{4}{3}(31) \left(\frac{10^{-3}}{1^2}\right)$$

$$= 41.33 \times 10^{-3} = 0.04133 \text{ N.m}$$

### Exercises | Q 22 | Page 130

Find the number of oscillations performed per minute by a magnet is vibrating in the plane of a uniform field of  $1.6 \times 10^{-5} \text{ Wb/m}^2$ . The magnet has a moment of inertia  $3 \times 10^{-6} \text{ kg/m}^2$  and magnetic moment  $3 \text{ A m}^2$ .

### SOLUTION

**Data:**  $B = 1.6 \times 10^{-5} \text{ T}$ ,  $I = 3 \times 10^{-6} \text{ kg/m}^2$ ,  $\mu = 3 \text{ A m}^2$

The period of oscillation,  $T = 2\pi \sqrt{\frac{I}{\mu B_h}}$

$\therefore$  The frequency of oscillation is

$$f = \frac{1}{2\pi} \sqrt{\frac{\mu B}{I}}$$

$\therefore$  The number of oscillations per minute

$$= 60f = \frac{60}{2\pi} \sqrt{\frac{3(1.6 \times 10^{-5})}{3 \times 10^{-6}}} = \frac{60}{2\pi} \sqrt{16} = \frac{120}{3.142}$$

$$= 38.19 \text{ osc/min.}$$

### Exercises | Q 23 | Page 130

A wooden block of mass  $m$  is kept on a piston that can perform vertical vibrations of adjustable frequency and amplitude. During vibrations, we don't want the block to leave the contact with the piston. How much maximum frequency is possible if the amplitude of vibrations is restricted to 25 cm? In this case, how much is the energy per unit mass of the block? ( $g \approx \pi^2 \approx 10 \text{ m/s}^2$ )

### SOLUTION

**Data:**  $A = 0.25 \text{ m}$ ,  $g = \pi^2 = 10 \text{ m/s}^2$

During vertical oscillations, the acceleration is maximum at the turning points at the top and bottom. The block will just lose contact with the piston when its apparent weight is zero at the top, i.e., when its acceleration is  $a_{\max} = g$ , downwards.

$$|a_{\max}| = \omega^2 A = 4\pi^2 f_{\max}^2 A$$

$$\therefore 4\pi^2 f_{\max}^2 A = g$$

$$\therefore f_{\max} = \sqrt{\frac{g}{\pi^2} \cdot \frac{1}{4A}}$$

$$= \sqrt{\frac{10}{10} \cdot \frac{1}{4(0.25)}} = 1 \text{ Hz}$$

This gives the required frequency of the piston.

$$E = \frac{1}{2} m \omega^2 A^2 = \frac{1}{2} m (4\pi^2 f^2) A^2$$

$$\therefore \frac{E}{m} = 2\pi^2 f^2 A^2 = 2(10)(1)^2 \left(\frac{1}{4}\right)^2$$

$$= \frac{20}{16} = \frac{5}{4} = 1.25 \text{ J/kg}$$